

1

2

3

4

NOTES:

- (1) PURGE ALL WATER SUPPLY LINES TO REMOVE SOLIDS PRIOR TO TOY INSTALLATION.
- (2) PROVIDE ELECTRICAL BOND WITH POOL REBAR.
- (3) INSTALL ALL WATER TOYS PLUMB AND LEVEL.
- (4) PROVIDE STRAINER UPSTREAM OF TOY WITH MAX 1/32" (0.8mm) PERFORATIONS.

A

A

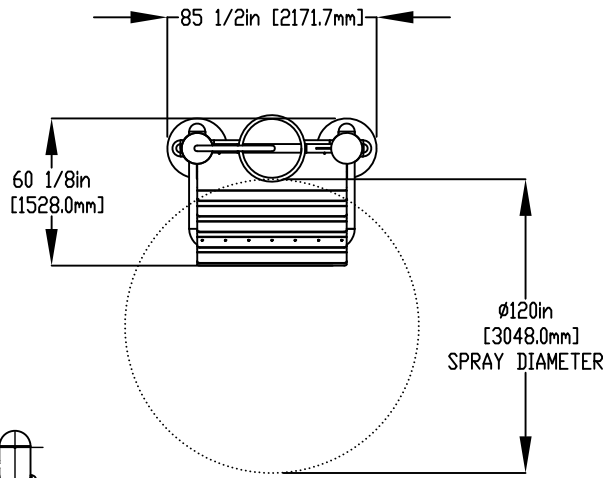

B

B

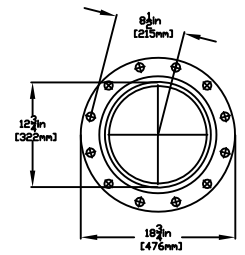
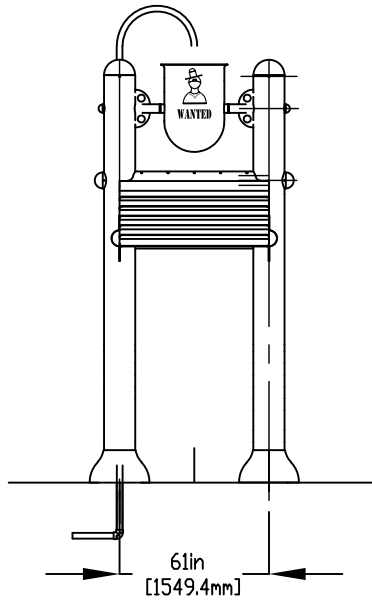
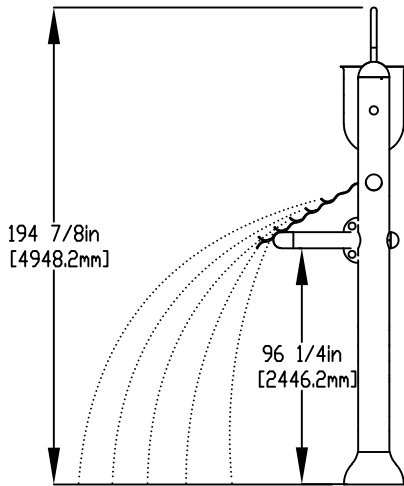

FLANGE DETAIL x2

C

C

D

D

2" (50mm) FLEX HOSE PROVIDED BY EMPEX

5/8" (16mm) X 9" (229mm) 316 SS THREADED ROD, C/W FENDER WASHER LOCK WASHER & NUT (X6) MINIMUM 6" EMBEDMENT, EPOXY SET ANCHOR ADHESIVE (EACH LEG) TO BE PROVIDED BY CONTRACTOR

2" (50mm) COUPLING
2" (50mm) HOSE BARB W/SS CLAMP TO BE PROVIDED BY CONTRACTOR

LOWER FLANGE COVERS AFTER TOY IS INSTALLED

(12) #4 @ 10" (250mm) Y-AXIS
(10) #4 @ 10" (250mm) Y-AXIS

(8) #4 @ 10" (250mm) X-AXIS

(4) #4 @ 10" (250mm) X-AXIS

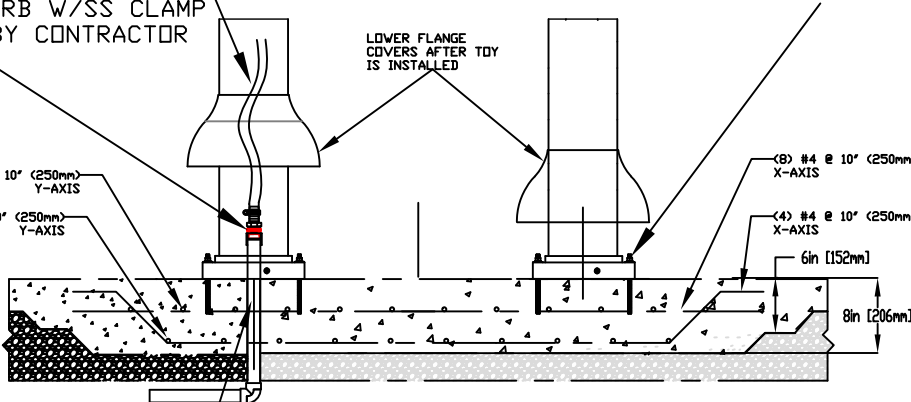

WATERFEED
2" (50mm) PVC SCH 40 PIPE
EXTENDED 6" (152mm) ABOVE SLAB.

F

F



Notes: Overall dimensions of toys are approximate.
Approximate Weight: 540lbs / 245.5kgs

© EMPEX WATERTOYS

WATER SUPPLY

70 gpm @ 25 psi
4.4 L/S @ 17.5m

AQUADUNKER

K024-AW

01/03/2021

SCALE:

Sheet 1 of 1

1

2

3

4