

NOTES:

- (1) PURGE ALL WATER SUPPLY LINES TO REMOVE SOLIDS PRIOR TO TOY INSTALLATION.
- (2) PROVIDE ELECTRICAL BOND WITH POOL REBAR.
- (3) INSTALL ALL WATER TOYS PLUMB AND LEVEL.
- (4) PROVIDE STRAINER UPSTREAM OF TOY WITH MAX 1/32" (0.08mm) PERFORATIONS.

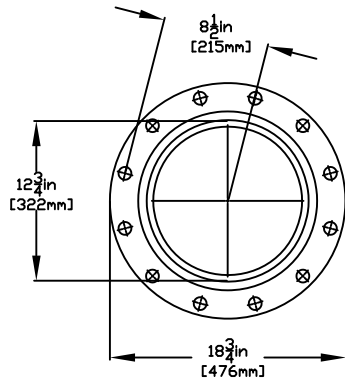

FLANGE DETAIL

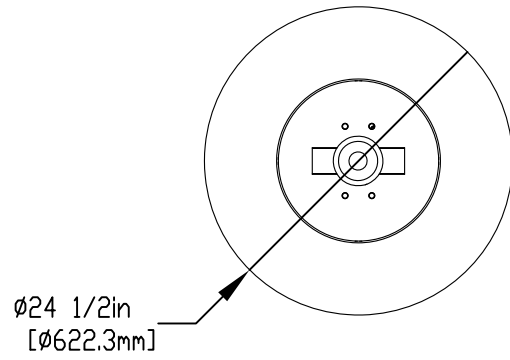
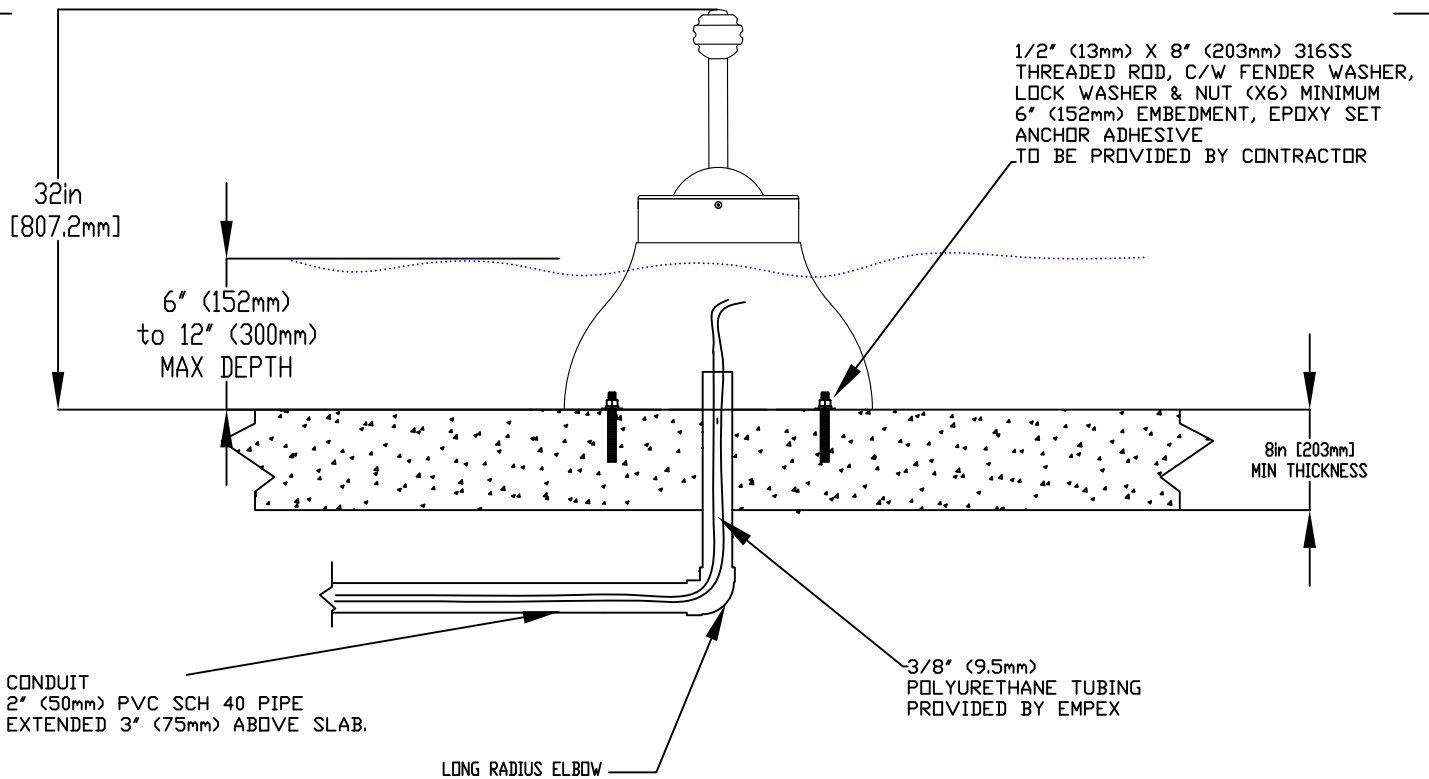

Notes: Overall dimensions of toys are approximate.

© EMPEX WATERTOYS

WATER SUPPLY
N/A

HAND PUMP

T136

SCALE:

Sheet
1 of 1